



ION Linear Barcode Scanner

The ION Linear is part of the cost-effective, high performance POS-X ION Series. It's a no-nonsense barcode scanner with outstanding speed and scan distance. With free 24/7 POS-X support and a 3-year warranty, this scanner guarantees high performance at a great value. This scanner is all business. Easy to set up right out of the box, just plug it in and get to work.



Key Features

- Reads compact barcodes as close as 3mil
- Optional presentation mode for hands-free scanning
- Reads up to 270 scans/second
- Reading distance: From 0.4" to 15.5"
- 3-Year Warranty includes 2-Day Advance Exchange Service

barcode scanner

ION Linear Specifications

PART NUMBER	ION-SP1-ACU
PERFORMANCE	
Light Source	Red LED 660 nm
Visual Indicators	Blue LED = decoding successful
System Interface	USB
Typical Depth of Field	0.4" (10mm) to 15.5" (390mm)
Resolution	3 mil
Scanning Angle	Pitch±65°, Skew±50°
Motion Tolerance	3.9inch/s (100mm/s)
Print Contrast	Minimum 45% contrast
Ambient Light Rejection	3000 lux-8000 lux
FEATURES	
Supported Symbologies	1D: UPC-A, UPC-E, EAN13, EAN8, Code39, Codabar, Code93, Code128, Interleaved 2 of 5, Industrial 2 of 5, Matrix 2 of 5, MSI/Plessey Code 32, Code 11, Telepen, GS1 Databar Omni, GS1 Databar Limited, GS1 Databar Expanded
Programmable Features	Presentation Mode, Prefix Code, Length Code, Barcode Type, ISBN/ISSN/CLSI/UK Plessey Conversion, Scanning Mode, Time Out, Baud Rate
PHYSICAL	
Weight	.22 lb (180g) w/cable
Housing	ABS
Dimensions	7.3"(186mm)(L)x 2.6"(67mm)(W)x 3.6"(91 mm)(H)
Color	Black
ELECTRICAL	5 VDC ± 0.25 V (input)
CURRENT	80mA
ENVIROMENTAL	
Temperature	32°- 104°F (0°C to 40°C) (operating)/-40°- 140°F (-40°C to 60°C) (storage)
Humidity	5% - 95% relative humidity, non-condensing
Shock Resistance	Withstands multiple drops from 3.9' (1.2 m)
WARRANTY	3-Year Includes 2-Day Advance Replacement Service
CERTIFICATIONS	SELV, CSA

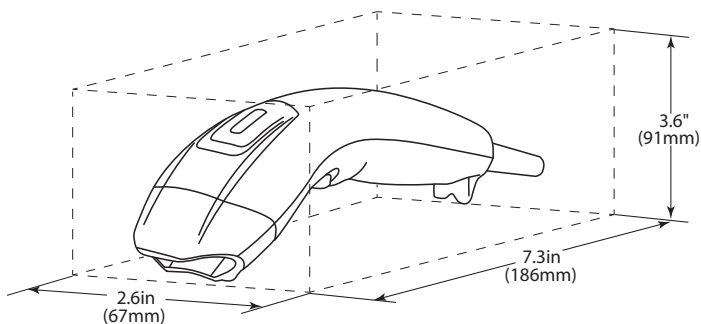

ACCESSORIES	
ION-SP1-ASTAND	ION Barcode Scanner stand
ZWE-BMP	2-Year Warranty Extension
ZOE-BMP3	3-Year Overnight Extension
ZOE-BMP5	5-Year Overnight Extension

Legacy Technology Services

We Rent & Sell All Types Of Barcode Equipment

Call now to talk to an expert

866-271-9891

www.LegacyGlobal.com

Some brands we carry



MOTOROLA

Intermec

DATALOGIC™

Honeywell

EQUINOX
PAYMENTS



About us

- Legacy Technology Services is a leading nationwide provider of mobile computing, barcode, printers and point of sale equipment and services.
- For over a decade, thousands of clients across North America have trusted us to provide equipment from leading manufacturers backed by the services to support them.

Latest Hardware from top manufacturers

- Legacy handles virtually every major manufacturer of mobile computing, barcoding and point of sale equipment.

Expert Repair and Maintenance services

- Legacy is one of the best repair facilities in North America

Discontinued product sourcing

- They don't make it anymore? Our inventory also includes manufacturer close-outs and discontinued equipment to support our clients legacy infrastructure.

Trade-in and Disposal services

- That old equipment laying around your facility may still have some value. Legacy routinely purchases equipment from our clients around the globe.
 - Data destruction
 - Hardware disposal
 - Auditing services

Dedicated client account team

- Dedicated, highly trained account managers are here to answer all your questions and provide top notch service.

Equipment rental services

- Sometimes renting is a better solution, Legacy's huge rental inventory provides the equipment you need for temporary needs and projects.



Legacy, Inc.

160 West Road,
Ellington, CT 06029

Toll Free: 866-271-9891

Fax: 888-522-4684